

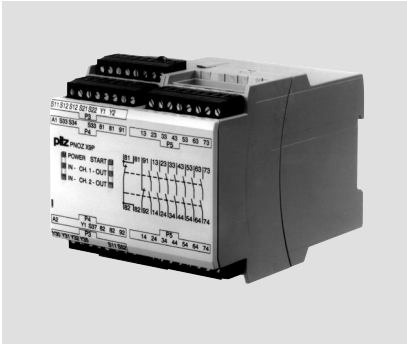



Up to Category 4, EN 954-1 PNOZ X9P



Safety relay for monitoring E-STOP pushbuttons, safety gates and light barriers.

Approvals

PNOZ X9P	
	◆
	◆
	◆

Order no. 777607 without approvals

Block diagram

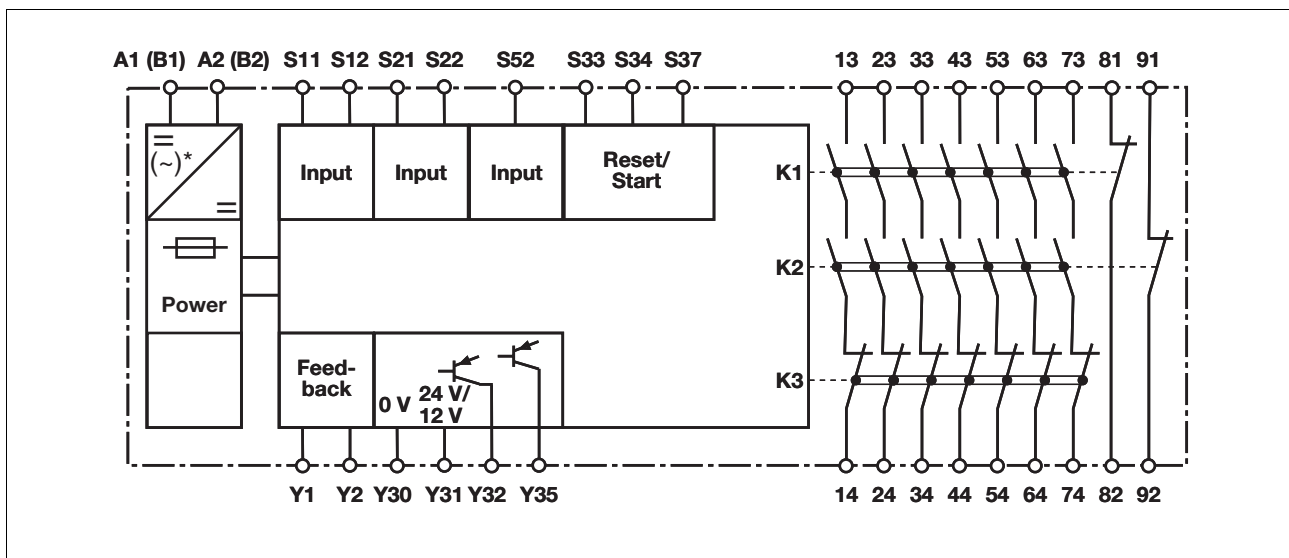

*Only applies when $U_B = 100 - 240 \text{ VAC}$

Unit features

- ▶ Positive-guided relay outputs:
 - 7 safety contacts (N/O), instantaneous
 - 2 auxiliary contacts (N/C), instantaneous
- ▶ 2 semiconductor outputs
- ▶ Connection options for:
 - E-STOP pushbutton
 - Safety gate limit switch
 - Light barriers
 - Reset button
- ▶ LED indicator for:
 - Switch status channel 1/2
 - Input circuits
 - Supply voltage
 - Reset circuit
- ▶ Semiconductor outputs signal:
 - Switch status channel 1/2
 - Supply voltage is present
- ▶ Plug-in connection terminals (either cage clamp terminal or screw terminal)
- ▶ See order reference for unit types

Unit description

The safety relay meets the requirements of EN 60947-5-1, EN 60204-1 and VDE 0113-1 and may be used in applications with

- ▶ E-STOP pushbuttons

- ▶ Safety gates
- ▶ Light barriers

Safety features

The relay meets the following safety requirements:

- ▶ The circuit is redundant with built-in self-monitoring.
- ▶ The safety function remains effective in the case of a component failure.
- ▶ The correct opening and closing of the safety function relays is tested automatically in each on-off cycle.
- ▶ The unit has an electronic fuse.

Up to Category 4, EN 954-1 PNOZ X9P

Function description

- ▶ Single-channel operation: no redundancy in the input circuit, earth faults in the reset and input circuit are detected.
- ▶ Dual-channel operation without detection of shorts across contacts: redundant input circuit, detects
 - earth faults in the reset and input circuit,
 - short circuits in the input circuit and, with a monitored reset, in the reset circuit too.
- ▶ Dual-channel operation with detection of shorts across contacts: redundant input circuit, detects
 - earth faults in the reset and input circuit,
 - short circuits in the input circuit and, with a monitored reset, in the reset circuit too,
 - shorts between contacts in the input circuit.
- ▶ Automatic start: Unit is active once the input circuit has been closed.
- ▶ Manual reset: Unit is active once the input circuit is closed and then the reset circuit is closed.
- ▶ Monitored reset: Unit is active once
 - the input circuit is closed and then the reset circuit is closed and opened again.
 - the reset circuit is closed and then opened again once the input circuit is closed.
- ▶ Increase in the number of available contacts by connecting contact expander modules or external contactors/relays.

Timing diagram

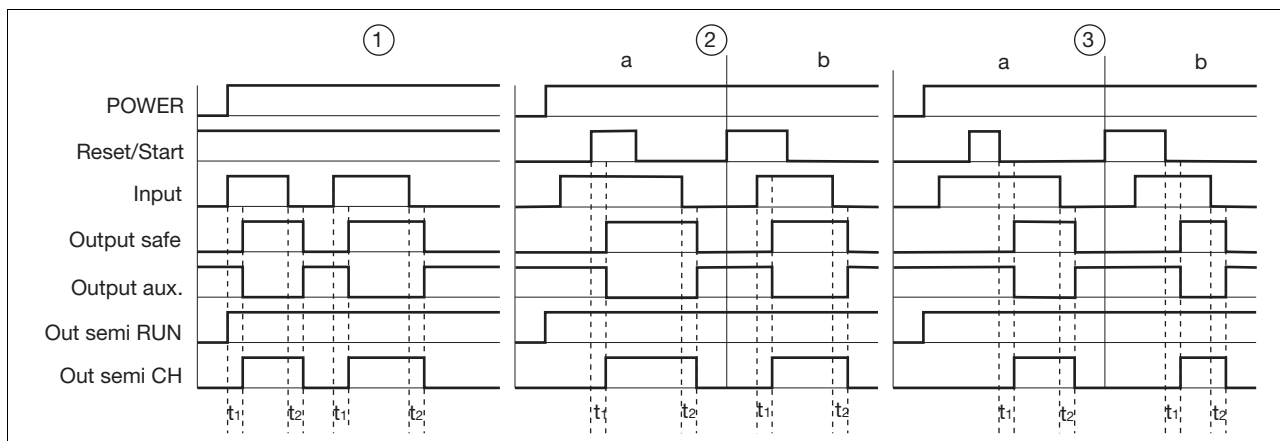

Key

- ▶ Power: Supply voltage
- ▶ Reset/start: Reset circuit S33-S34
- ▶ Input: Input circuits S11-S12, S21-S22, S52
- ▶ Output safe: Safety contacts 13-14, 23-24, 33-34, 43-44, 53-54, 63-64, 73-74
- ▶ Output aux.: Auxiliary contacts 81-82, 91-92
- ▶ Out semi RUN: Semiconductor output supply voltage Y35
- ▶ Out semi CH: Semiconductor output switch status Y32
- ▶ ①: Automatic reset
- ▶ ②: Manual reset
- ▶ ③: Monitored reset
- ▶ a: Input circuit closes before reset circuit
- ▶ b: Reset circuit closes before input circuit
- ▶ t₁: Switch-on delay
- ▶ t₂: Delay-on de-energisation

Wiring

Please note:

- ▶ Information given in the “Technical details” must be followed.
- ▶ Outputs 13-14, 23-24, 33-34, 43-44, 53-54, 63-64, 73-74 are safety contacts, outputs 81-82, 91-92 are auxiliary contacts (e.g. for display).
- ▶ To prevent contact welding, a fuse should be connected before the output contacts (see technical details).
- ▶ Calculation of the max. cabling runs I_{max} in the input circuit:

$$I_{max} = \frac{R_{lmax}}{R_l / km}$$



R_{lmax} = max. overall cable resistance (see technical details)
 R_l / km = cable resistance/km

- ▶ Use copper wire that can withstand 60/75 °C.
- ▶ Sufficient fuse protection must be provided on all output contacts with capacitive and inductive loads.





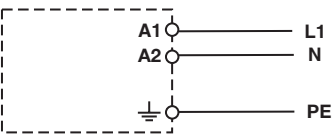
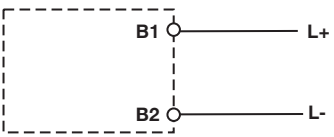

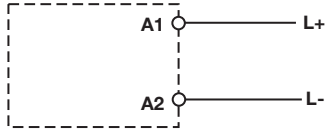
Up to Category 4, EN 954-1 PNOZ X9P

Preparing for operation

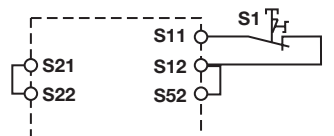
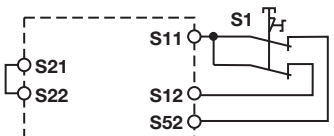
► Supply voltage

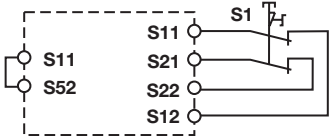
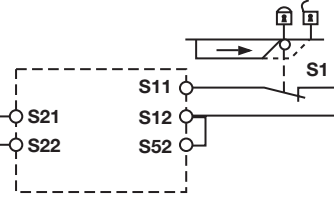
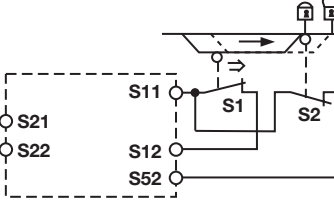

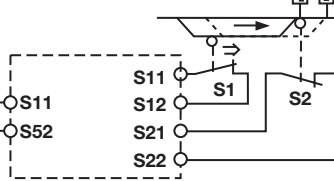
Supply voltage	AC	DC
$U_B = 12 \text{ V DC}/24 \text{ VDC}/100 - 240 \text{ VAC}$		
$U_B = 12 \text{ V DC}/24 \text{ VDC}$		

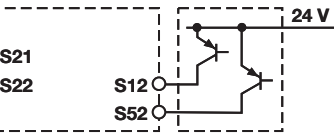
► Input circuit

Input circuit	Single-channel	Dual-channel
E-STOP without detection of shorts across contacts		
E-STOP with detection of shorts across contacts		
Safety gate without detection of shorts across contacts		
Safety gate with detection of shorts across contacts		
Light barrier with detection of shorts across contacts via ESPE		

Up to Category 4, EN 954-1 PNOZ X9P

▶ Reset circuit

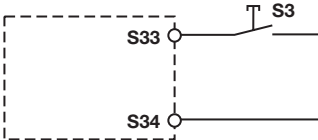
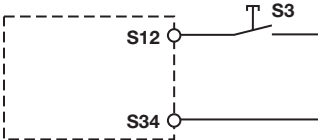
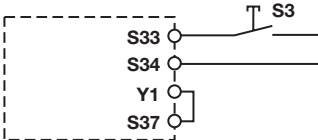
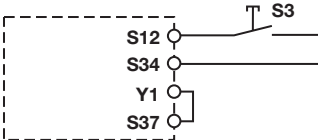
Reset circuit	E-STOP/safety gate wiring (single and dual-channel, without shorts across contacts)	E-STOP/safety gate wiring (dual-channel with shorts across contacts)
Automatic reset		
Manual reset		
Monitored reset		

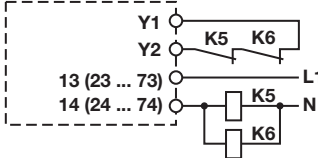

▶ Feedback loop

Feedback loop	
Contacts from external contactors	

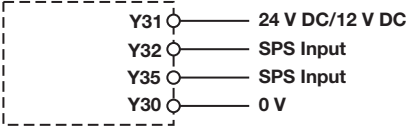
▶ Semiconductor output

--

▶ Key

S1/S2	E-STOP/safety gate switch
S3	Reset button
	Switch operated
	Gate open
	Gate closed

Up to Category 4, EN 954-1 PNOZ X9P

Terminal configuration

$U_B = 12\text{ V DC}/24\text{ VDC}$

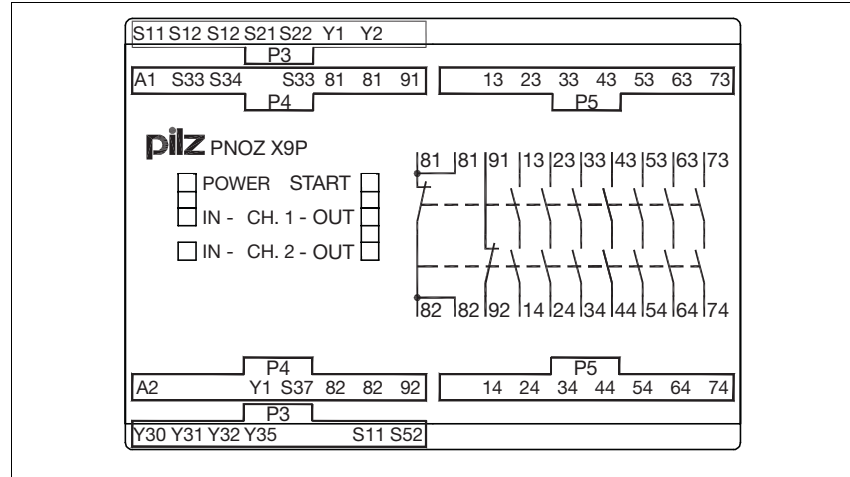

$U_B = 24\text{ VDC}/100\text{ -}240\text{ VAC}$

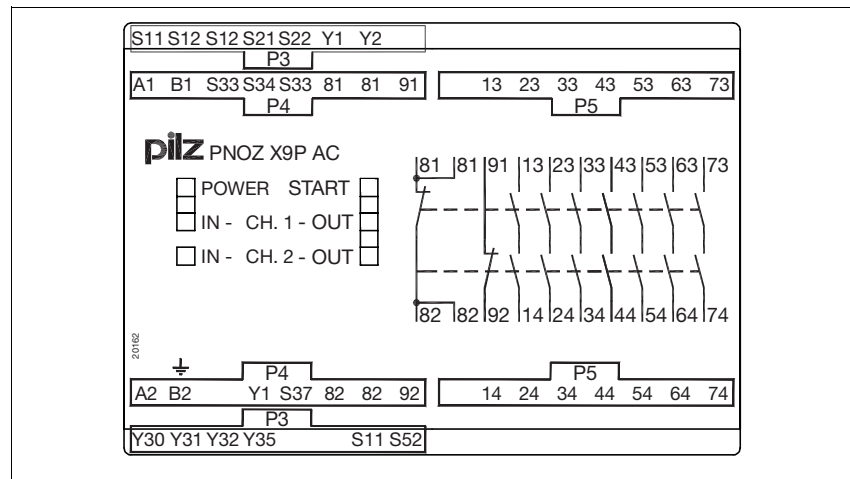

Installation

- ▶ The safety relay should be installed in a control cabinet with a protection type of at least IP54.
- ▶ Use the notch on the rear of the unit to attach it to a DIN rail.
- ▶ Ensure the unit is mounted securely on a vertical DIN rail (35 mm) by using a fixing element (e.g. retaining bracket or an end angle).

Dimensions

* with cage clamp terminals

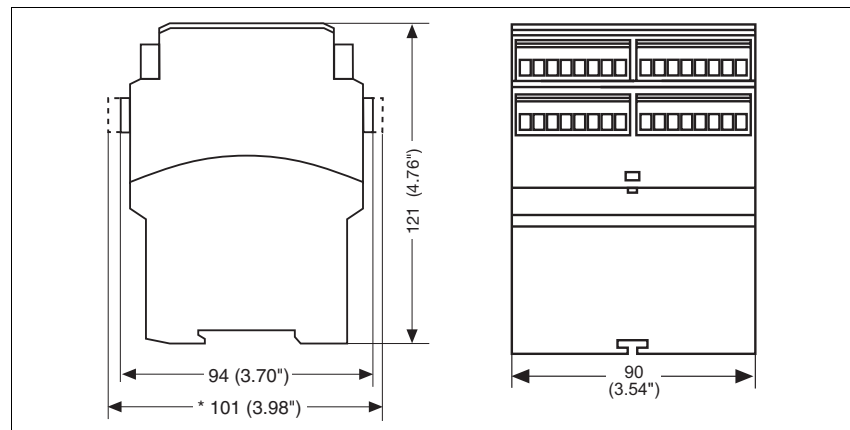

Up to Category 4, EN 954-1 PNOZ X9P

Notice

This data sheet is only intended for use during configuration. For installation and operation, please refer to the operating instructions supplied with the unit.

Service life graph

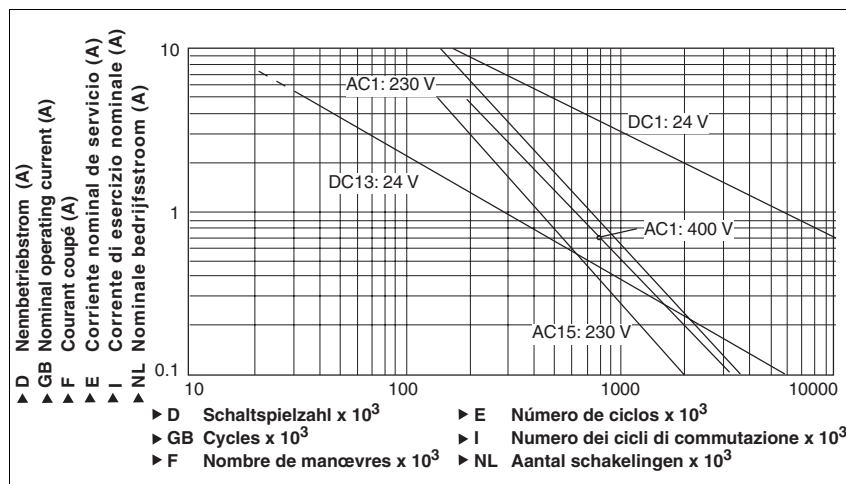

Technical details

Electrical data

Supply voltage	
Supply voltage U _B AC	100 - 240 V
Supply voltage U _B DC	12 V, 24 V
Voltage tolerance	-15 %/+10 % Order no.: 777606, 777609, 787606, 787609 -20 %/+20 % Order no.: 777607
Power consumption at U _B AC	8.5 VA Order no.: 777606, 787606
Power consumption at U _B DC	5.5 W Order no.: 777606, 777609, 787606, 787609 7.0 W Order no.: 777607
Frequency range AC	50 - 60 Hz
Residual ripple DC	160 %
Voltage and current at	
Input circuit DC: 12.0 V Order no.: 777607	130.0 mA Order no.: 777607
24.0 V Order no.: 777606, 777609, 787606, 787609	50.0 mA Order no.: 777606, 777609, 787606, 787609
Reset circuit DC: 12.0 V Order no.: 777607	100.0 mA Order no.: 777606, 777609, 787606, 787609
24.0 V Order no.: 777606, 777609, 787606, 787609	200.0 mA Order no.: 777607
Feedback loop DC: 12.0 V Order no.: 777607	100.0 mA Order no.: 777606, 777609, 787606, 787609
24.0 V Order no.: 777606, 777609, 787606, 787609	200.0 mA Order no.: 777607
Number of output contacts	
Safety contacts (S) instantaneous:	7
Auxiliary contacts (N/C):	2
Category of output contacts in accordance with EN 954-1	
Safety contacts (S) instantaneous:	4

Up to Category 4, EN 954-1 PNOZ X9P

Electrical data

Utilisation category in accordance with EN 60947-4-1	
Safety contacts: AC1 at 240 V	I_{\min} : 0.01 A , I_{\max} : 8.0 A P_{\max} : 2000 VA
Safety contacts: DC1 at 24 V	I_{\min} : 0.01 A , I_{\max} : 8.0 A P_{\max} : 200 W
Auxiliary contacts: AC1 at 240 V	I_{\min} : 0.01 A , I_{\max} : 8.0 A P_{\max} : 2000 VA
Auxiliary contacts: DC1 at 24 V	I_{\min} : 0.01 A , I_{\max} : 8.0 A P_{\max} : 200 W
Utilisation category in accordance with EN 60947-5-1	
Safety contacts: AC15 at 230 V	I_{\max} : 5.0 A
Safety contacts: DC13 at 24 V (6 cycles/min)	I_{\max} : 7.0 A
Auxiliary contacts: AC15 at 230 V	I_{\max} : 5.0 A
Auxiliary contacts: DC13 at 24 V (6 cycles/min)	I_{\max} : 7.0 A
Contact material	AgSnO₂ + 0.2 µm Au
External contact fuse protection ($I_K = 1 \text{ kA}$) to EN 60947-5-1	
Blow-out fuse, quick	
Safety contacts:	10 A
Auxiliary contacts:	10 A
Blow-out fuse, slow	
Safety contacts:	6 A
Auxiliary contacts:	6 A
Circuit breaker 24 VAC/DC, characteristic B/C	
Safety contacts:	6 A
Auxiliary contacts:	6 A
Semiconductor outputs (short circuit proof)	12.0 V Order no.: 777607 24.0 V Order no.: 777606, 777609, 787606, 787609 DC, 20 mA
External supply voltage	12.0 V Order no.: 777607 24.0 V Order no.: 777606, 777609, 787606, 787609 DC
Voltage tolerance	-20 %/+20 %
Max. overall cable resistance $R_{i\max}$ input circuits, reset circuits	
single-channel at U_B DC	45 Ohm Order no.: 777606, 777609, 787606, 787609 8 Ohm Order no.: 777607
single-channel at U_B AC	45 Ohm Order no.: 777606, 787606
dual-channel without detect. of shorts across contacts at U_B DC	15 Ohm Order no.: 777607 90 Ohm Order no.: 777606, 777609, 787606, 787609
dual-channel without detect. of shorts across contacts at U_B AC	90 Ohm Order no.: 777606, 787606
dual-channel with detect. of shorts across contacts at U_B DC	15 Ohm Order no.: 777606, 777609, 787606, 787609 8 Ohm Order no.: 777607
dual-channel with detect. of shorts across contacts at U_B AC	15 Ohm Order no.: 777606, 787606

Up to Category 4, EN 954-1 PNOZ X9P

Times	
Switch-on delay	
with automatic reset typ.	130 ms Order no.: 777607
	200 ms Order no.: 777606, 777609, 787606, 787609
with automatic reset max.	200 ms Order no.: 777607
	250 ms Order no.: 777606, 777609, 787606, 787609
with automatic reset after power on typ.	150 ms Order no.: 777607
	220 ms Order no.: 777606, 777609, 787606, 787609
with automatic reset after power on max.	220 ms Order no.: 777607
	300 ms Order no.: 777606, 777609, 787606, 787609
with manual reset typ.	150 ms Order no.: 777607
	200 ms Order no.: 777606, 777609, 787606, 787609
with manual reset max.	200 ms Order no.: 777607
	250 ms Order no.: 777606, 777609, 787606, 787609
on monitored reset with falling edge typ.	100 ms Order no.: 777607
	150 ms Order no.: 777606, 777609, 787606, 787609
on monitored reset with falling edge max.	150 ms Order no.: 777607
	220 ms Order no.: 777606, 777609, 787606, 787609
Delay-on de-energisation	
with E-STOP typ.	20 ms
with E-STOP max.	30 ms
with power failure typ.	170 ms Order no.: 777606, 777609, 787606, 787609
	60 ms Order no.: 777607
with power failure max.	250 ms Order no.: 777606, 777609, 787606, 787609
	80 ms Order no.: 777607
with power failure typ. U_B AC: 100 V, 100 V	165 ms Order no.: 777606, 787606
with power failure max. U_B AC: 100 V, 100 V	200 ms Order no.: 777606, 787606
with power failure typ. U_B AC: 240 V	320 ms Order no.: 777606, 787606
with power failure max. U_B AC: 240 V	450 ms Order no.: 777606, 787606
Recovery time at max. switching frequency 1/s	
after E-STOP	50 ms
after power failure	100 ms Order no.: 777607
	300 ms Order no.: 777606, 777609, 787606, 787609
after power failure on universal power supply	500 ms Order no.: 777606, 787606
Min. start pulse duration with a monitored reset	
with falling edge	30 ms Order no.: 777607
	50 ms Order no.: 777606, 777609, 787606, 787609
Simultaneity, channel 1 and 2	150 ms Order no.: 777606, 777609, 787606, 787609
	50 ms Order no.: 777607
Supply interruption before de-energisation	20 ms
Environmental data	
EMC	EN 60947-5-1, EN 61000-6-2
Vibration to EN 60068-2-6	
Frequency	10 - 55 Hz
Amplitude	0.35 mm
Climatic suitability	EN 60068-2-78
Airgap creepage	EN 60947-1 Order no.: 777607, 777609, 787609 VDE 0110-1 Order no.: 777606, 787606
Rated insulation voltage	250 V
Rated impulse withstand voltage	4.0 kV
Ambient temperature	-10 - 55 °C
Storage temperature	-40 - 85 °C
Protection type	
Mounting (e.g. cabinet)	IP54
Housing	IP40
Terminals	IP20

Up to Category 4, EN 954-1 PNOZ X9P

Mechanical data

Housing material	
Housing	PPO UL 94 V0
Front	ABS UL 94 V0
Max. cross section of external conductors with screw terminals	
1 core flexible	0.25 - 2.50 mm², 24 - 12 AWG Order no.: 777606, 777607, 777609
2 core, same cross section, flexible:	
with crimp connectors, without insulating sleeve	0.25 - 1.00 mm², 24 - 16 AWG Order no.: 777606, 777607, 777609
without crimp connectors or with TWIN crimp connectors	0.20 - 1.50 mm², 24 - 16 AWG Order no.: 777606, 777607, 777609
Torque setting with screw terminals	0.50 Nm Order no.: 777606, 777607, 777609
Max. cross section of external conductors with cage clamp terminals/spring-loaded terminals: Flexible without crimp connectors	0.20 - 1.50 mm², 24 - 16 AWG Order no.: 787606, 787609
Cage clamp terminals/spring-loaded terminals: Terminal points per connection	2 Order no.: 787606, 787609
Stripping length	8 mm Order no.: 787606, 787609
Dimensions	
Height	101.0 mm Order no.: 787606, 787609 94.0 mm Order no.: 777606, 777607, 777609
Width	90.0 mm
Depth	121.0 mm
Weight	570 g Order no.: 787609 575 g Order no.: 787606 580 g Order no.: 777607, 777609 585 g Order no.: 777606

The standards current on **2006-06** apply.

Conventional thermal current

Number of contacts	I_{th} (A) at U_B DC	I_{th} (A) at U_B AC
1	8.00 A	8.00 A Order no.: 777606, 787606
2	8.00 A	8.00 A Order no.: 777606, 787606
3	8.00 A	8.00 A Order no.: 777606, 787606
4	7.00 A	7.00 A Order no.: 777606, 787606
5	6.00 A	6.00 A Order no.: 777606, 787606
6	5.50 A	5.50 A Order no.: 777606, 787606
7	5.00 A	5.00 A Order no.: 777606, 787606

Order reference

Type	Features	Terminals	Order no.
PNOZ X9P C	110 - 240 VAC 24 VDC	Cage clamp terminals	787 606
PNOZ X9P	110 - 240 VAC 24 VDC	Screw terminals	777 606
PNOZ X9P C	24 VDC	Cage clamp terminals	787 609
PNOZ X9P	24 VDC	Screw terminals	777 609
PNOZ X9P	12 V DC	Screw terminals	777 607